

3M™ Mining Cable Splice Kit 3103 Instructions

Kit Contents:

- 2 Scotch® Heavy Duty Mining Tape 31, 2" x 8.5'
- 1 3M™ Temflex™ Vinyl Electrical Tape 1700P, 1½" x 44'
- 3 Scotch® Electrical Shielding Tape 24, 2" x 10'
- 2 Scotch® Rubber Mastic Tape 2228, 1" x 10'
- 2 3M™ Cable Cleaning Preparation Kit CC-2-Dry
- 3 Scotch® Electrical Semi-conductive Tape 13, ¾" x 15'
- 3 Scotch® Linerless Rubber Splicing Tape 130C, 1½" x 30'
- 3 Scotch® Linerless Rubber Splicing Tape 130C, ¾" x 30'
- 1 Instruction Sheet

Note: Scotch® Linerless Rubber Splicing Tape 130C is applied tacky side UP for primary insulation, and tacky side DOWN for cable jacket build-up.

Technical Information:

For use on 3-conductor mine and portable cables, type SHD-GC, MPF-GC and MPF #6 AWG–1 AWG (14–38 mm²)
5, 8, 15 kV
Cables up to 500 kcmil (250 mm²) will require the use of additional tapes.

Mine Safety and Health Administration Acceptance:

P-07-KA080005/00-MSHA

⚠ DANGER

Before attempting any cable repairs, make sure that the proper cable is disconnected, locked out and suitably tagged.

⚠ CAUTION

Working around energized systems may cause serious injury or death. Installation should be performed by personnel familiar with good safety practice in handling electrical equipment. De-energize and ground all electrical systems before installing product.

August 2009
78-8127-6848-5-C

3M

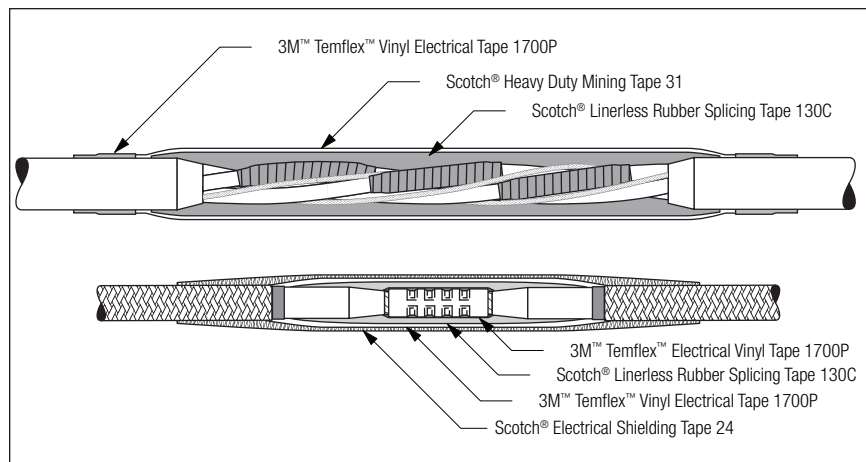

1.0 Prepare Cable

- 1.1 Position cable ends so that conductor color rotation matches.
- 1.2 Circle-cut cable jacket approximately 12" (305 mm) from each end. Be sure not to damage cable conductors.
- 1.3 Measure approximately 14" (355 mm) from cable end and fully taper cable jacket down to circle cut.

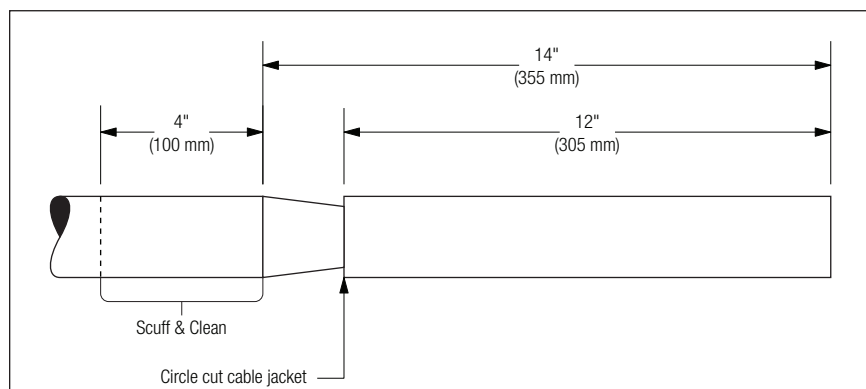

- 1.4 Remove approximately 12" (305 mm) of cable jacket.
- 1.5 Scuff and clean 4" (100 mm) of cable jacket beyond top of taper.
- 1.6 Remove cable fillers.
- 1.7 Fold back grounds and ground check conductors and temporarily tape to cable jacket with vinyl tape.

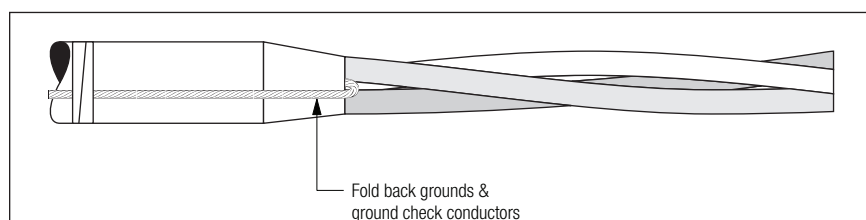

- 1.8 Select one conductor and cut conductor approximately 9" (230 mm). Match this conductor with same color conductor on opposite end.
- 1.9 Take next conductor in rotation and cut approximately 6" (150 mm) from end.

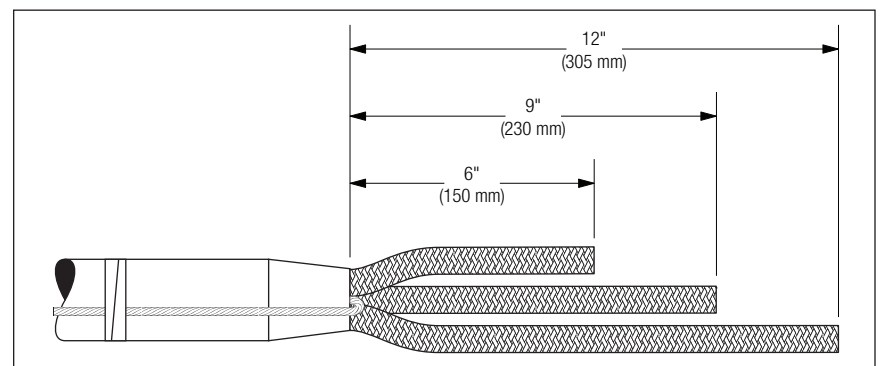

- 1.10 From the end of each conductor cutback remove 3½" (90 mm) of braid (or tape) metallic shielding.
- 1.11 Remove cable semi-con to ¼" (6 mm) from edge of shielding.
- 1.12 Remove insulation from ends of conductors for one-half connector length plus ¼" (6 mm).
- 1.13 Pencil insulation for ¾" (20 mm), sand smooth and even with electrical grade abrasive cloth from cable cleaning materials.

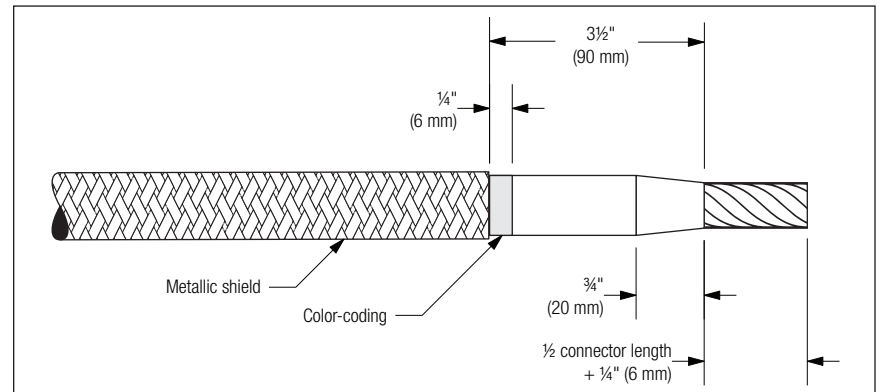

2.0 Connect Phase Conductors

- 2.1 Join power conductors with proper connectors and appropriate crimping tool. Make certain conductors butt up to center indents of connector.

Note: Ground wires and ground check will be joined later.

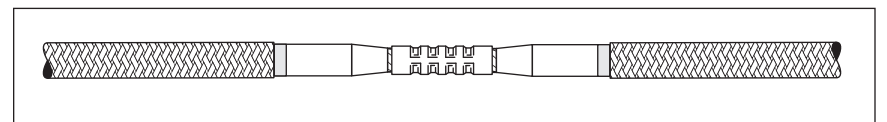

3.0 Apply Primary Insulation

- 3.1 Apply two highly-stretched half-lapped layers of Scotch® Electrical Semi-conducting Tape 13 from edge of taper to edge of taper, making sure to completely cover exposed cable semi-con at edge of each taper.

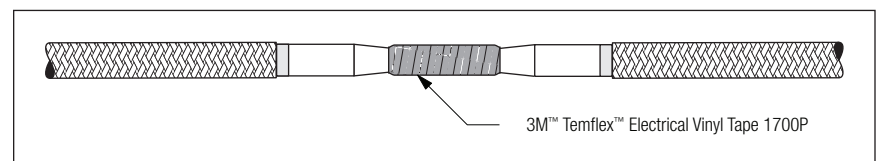

- 3.2 Apply highly-stretched half-lapped layers of Scotch® Linerless Rubber Splicing Tape 130C (tacky side UP) over the 13 tape and up onto tapers. Build up half-lapped layers of tape gradually going out on existing insulation to 1/8" (3 mm) from edge of original cable semi-con. Tape should be wrapped to a thickness equal to or greater than original insulation.

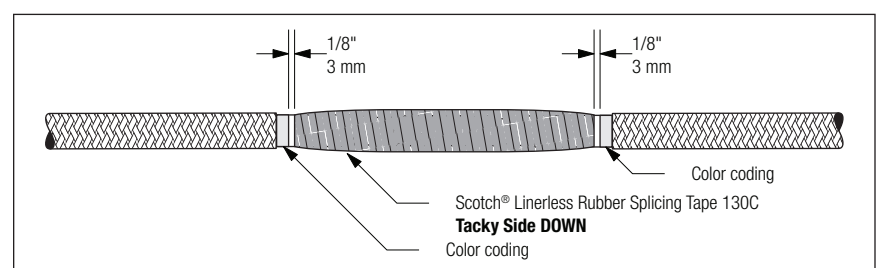

- 3.3 Apply two highly-stretched half-lapped layers of 13 tape over the 130C tape overlapping the edges of the metallic shielding.

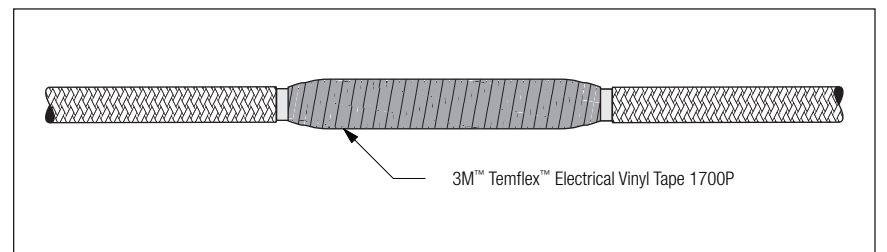

- 3.4 Starting 2" (50 mm) up on exposed metallic shielding, wrap one half-lapped layer of Scotch® Electrical Shielding Tape 24 over the semi-conducting tape continuing onto opposite shielding for 2" (50 mm). Wrap back down the shielding, secure with a half hitch or square knot, and trim ends.

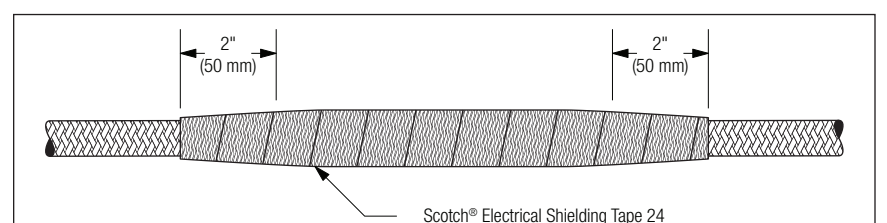

- 3.5 Repeat sections 2.0 & 3.0 for remaining phases.

4.0 Connect Ground Connectors

- 4.1 Before cutting ground wires, reposition the spliced power conductors so that the conductors are returned to the natural helix of the cable.
- 4.2 Lay the ground wires in their natural position in the valley between two power conductors. Cut ground to lengths staggered to avoid connection over power conductor connections.
- 4.3 Join conductors with proper connectors and appropriate crimping tool.
- 4.4 If present, connect the ground check conductor after trimming to proper length and removing one-half connector length of insulation from each lead. Use proper connector and crimping tool.
- 4.5 On ground check, clean the insulation 1" (25 mm) on both sides of the connection and apply one half-lapped layer of 3M™ Temflex™ Vinyl Electrical Tape 1700P, one half-lapped layer Scotch® Linerless Rubber Splicing Tape 130C (tacky side up), and one half-lapped layer of 1700P tape over the connector and the cleaned insulation.

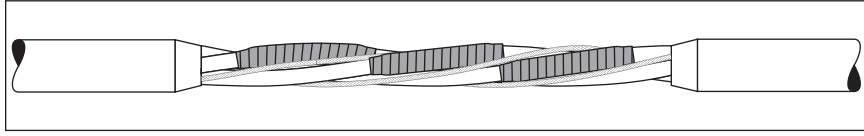

- 4.6 Connect remaining ground wires.

5.0 Jacketing the Splice

- 5.1 Bundle cable assembly and bind with 1700P tape. Starting half way up the tapers, wrap half-lapped layers of 130C tape (**tacky side DOWN**), building up and across the splice until tape is equal to or greater than original jacket thickness and extends 1" (25 mm) past the top of jacket tapers.

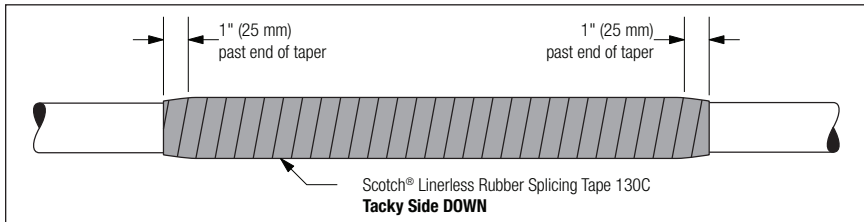

- 5.2 Start 2" (50 mm) beyond 130C tape, wrap one half-lapped layer of Scotch® Heavy Duty Mining Tape 31 with mastic side toward the cable extending 2" (50 mm) beyond the 130C tape on the opposite end. Always wrap the 31 tape toward the machine end of the cable.

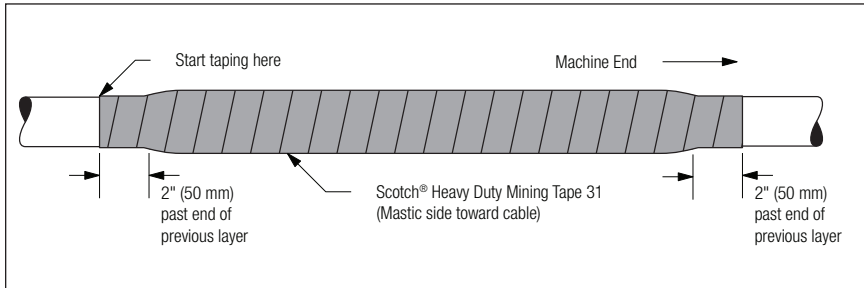

- 5.3 Starting 1" (25 mm) past the 31 tape, apply 3 half-lapped layers of 1700P tape to each end to temporarily secure the ends of the 31 tape jacket until the jacket reaches full bond.

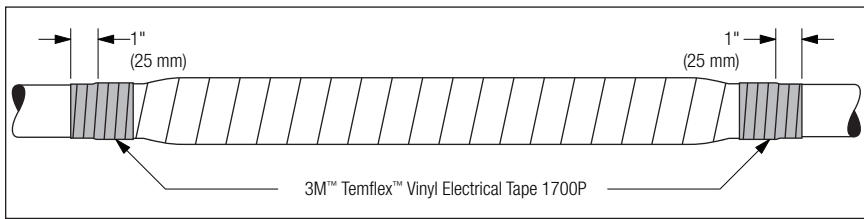

6.0 Repairing Damaged Cable Jacket

Note: For jacket repair option, additional tape may be needed for longer repairs.

- 6.1 Remove damaged cable jacket and taper jacket approximately 2" (50 mm).
- 6.2 Scuff and clean 4" (100 mm) of cable jacket beyond each split end.

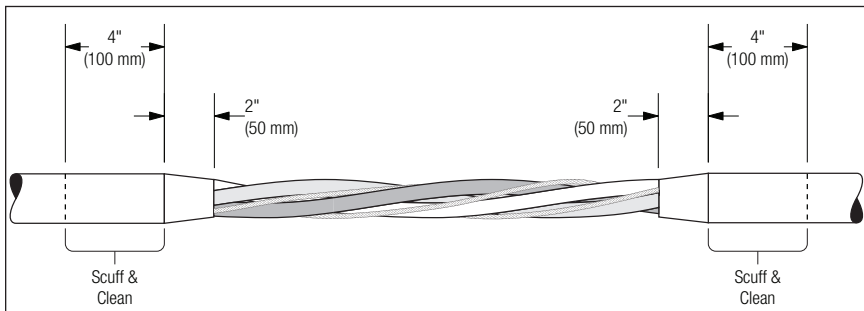

- 6.3 Starting half way up the tapers, bind phase conductors with one half-lapped layer of 130C tape (**tacky side DOWN**).

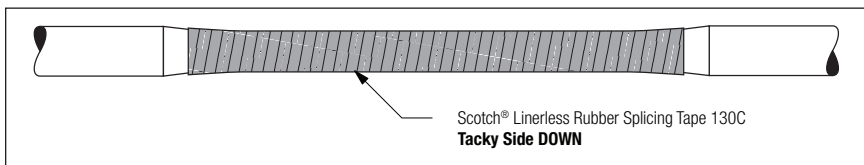

- 6.4 Cover splicing tape with one half-lapped layer of Scotch® Rubber Mastic Tape 2228.

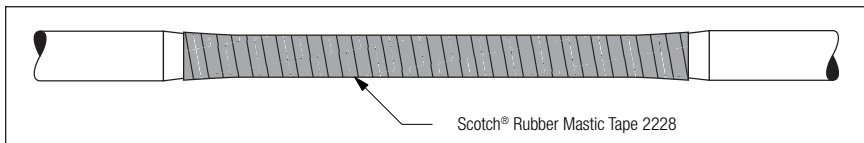

- 6.5 Wrap half-lapped layers of 130C tape (**tacky side DOWN**) building up and across the splice until equal to or greater than original jacket thickness and extends 1" (25 mm) past the top of jacket tapers.

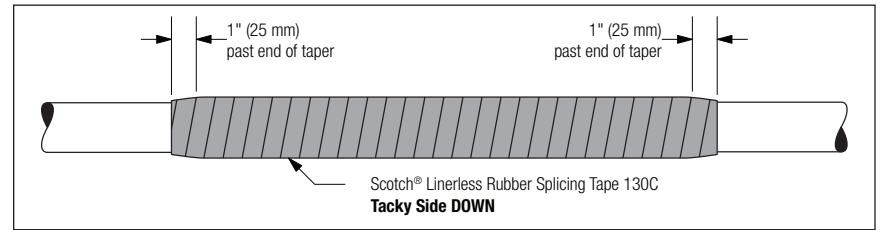

- 6.6 Start 2" (50 mm) beyond 130C tape, wrap one half-lapped layer of 31 tape with mastic side toward the cable extending 2" (50 mm) beyond the 130C tape on the opposite end. Always wrap the 31 tape toward the machine end of the cable.

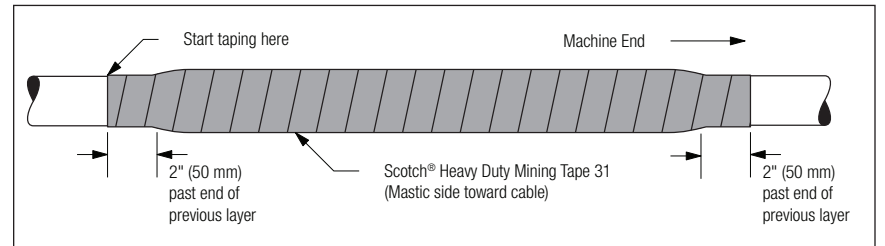

- 6.7 Starting 1" (25 mm) past the 31 tape, apply 3 half-lapped layers of 1700P tape to each end to temporarily secure the ends of the 31 tape until the tape reaches full bond.

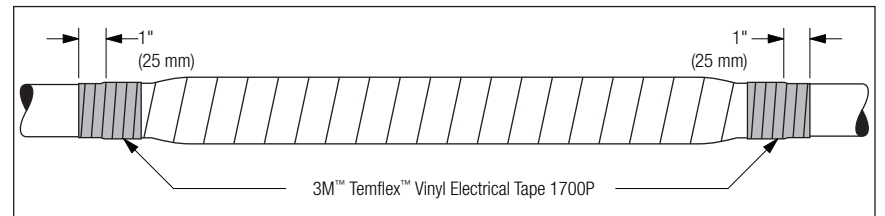

7.0 For Conduit Repair and Splicing

- 7.1 If splicing, cut conduit at 30–45° angle.

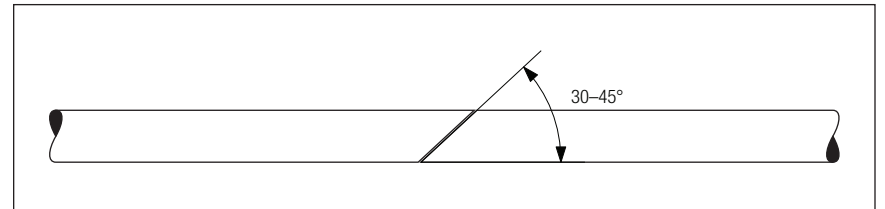

- 7.2 Clean and abrade conduit surface.

- 7.3 Fill voids using 130C tape.

- 7.4 Apply one half-lapped layer of 31 tape beginning and ending a minimum of 4" (102 mm) from each side of the conduit cut or repair location.

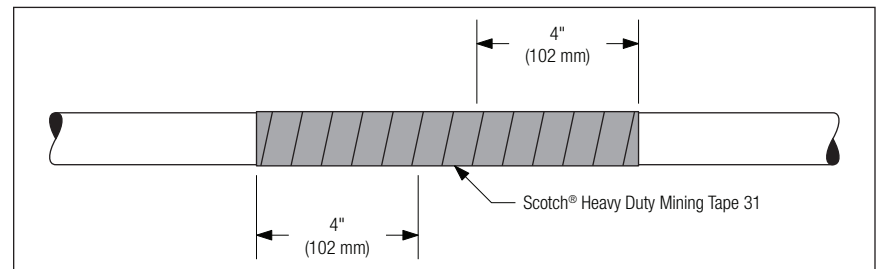

- 7.5 Starting 1" (25 mm) past the 31 tape, apply 3 half-lapped layers of 1700P tape to each end to temporarily secure the ends of the 31 tape until the tape reaches full bond.

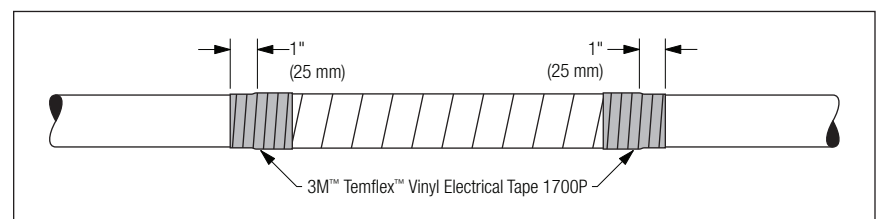

Important Notice

All statements, technical information, and recommendations related to 3M's products are based on information believed to be reliable, but the accuracy or completeness is not guaranteed. Before using this product, you must evaluate it and determine if it is suitable for your intended application. You assume all risks and liability associated with such use. Any statements related to the product which are not contained in 3M's current publications, or any contrary statements contained on your purchase order shall have no force or effect unless expressly agreed upon, in writing, by an authorized officer of 3M.

Warranty; Limited Remedy; Limited Liability.

This product will be free from defects in material and manufacture at the time of purchase. **3M MAKES NO OTHER WARRANTIES INCLUDING, BUT NOT LIMITED TO, ANY IMPLIED WARRANTY OF MERCHANTABILITY OR FITNESS FOR A PARTICULAR PURPOSE.** If this product is defective within the warranty period stated above, your exclusive remedy shall be, at 3M's option, to replace or repair the 3M product or refund the purchase price of the 3M product. **Except where prohibited by law, 3M will not be liable for any indirect, special, incidental or consequential loss or damage arising from this 3M product, regardless of the legal theory asserted.**

3M

Electrical Markets Division

6801 River Place Blvd.
Austin, TX 78726-9000
800-245-3523
Fax 800-245-0329
www.3M.com/electrical

3M and Temflex are trademarks of 3M Company.
Scotch is a registered trademark of 3M Company.

Please Recycle. Printed in USA.
© 3M 2009. All Rights Reserved.
78-8127-6848-5-C