

Flex-Tone Explosionproof Electronic Signals ETH655 & ETH855

Installation & Maintenance Information

IF 1494

SAVE THESE INSTRUCTIONS FOR FUTURE REFERENCE

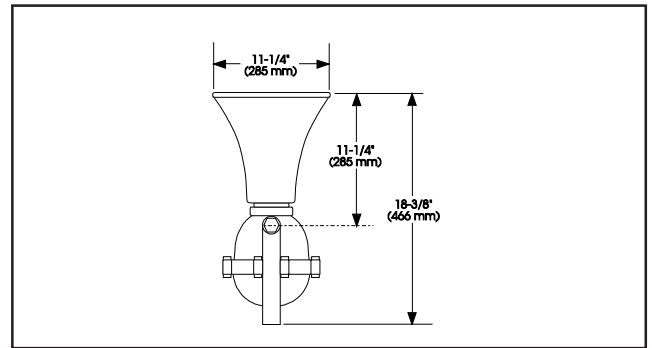
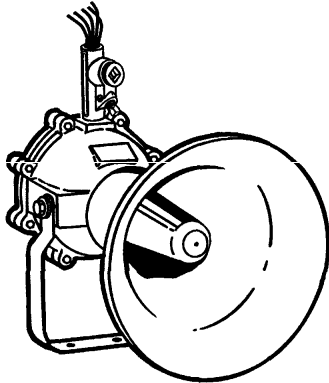

Figure 1. Dimensions

Description and Operation

Cooper Crouse-Hinds Hazardous Location Use Flex-Tone is a heavy-duty, stand-alone audible signaling device intended for industrial applications where high audible output, safety in a hazardous location and microcomputer reliability are required. The Flex-Tones are listed for installation in the following hazardous locations:

Catalog Series	Class	Zones	Divisions	Groups
ETH655	I		1 and 2	B, C and D
ETH855	I	1 and 2		IIA and IIB

The Flex-Tone operates from local power. Each unit accommodates two different inputs that will sound selected tones. Tone descriptions are listed in Table 1. Tones are programmed by setting miniature switches within the unit. Settings for all tones are listed on the inside of the Flex-Tone housing cap.

Speaker direction and output level are easily adjustable.

Mechanical Specifications

Weight 18.4 Pounds (8.4 kg)
 Variable Ambient Temp. 32F to 104F (0C to 40C)

Electrical Specifications

Catalog Number	INPUT POWER Voltage	Typical Current (A)	
		Standby	Tone On
		ETH655/24	24V AC 50/60 Hz
ETH655/120	120V AC 50/60 Hz	0.088	0.26
ETH655/240	240V AC 50/60 Hz	0.091	0.19
ETH855/24	24V DC	0.061	0.25
ETH855/36	36V DC	0.077	0.38
ETH855/125	125V DC	0.031	0.130
ETH855/250	250V DC	0.019	0.070

Installation

Installation is to be in accordance with the latest edition of the National Electrical Code or the Canadian Electrical Code, as applicable, and in accordance with the authorities having jurisdiction.

1. Mount Flex-Tone to any solid surface using its mounting bracket and (3) bolts (not supplied) (Figure 1).



WARNING

Keep mating surfaces of housing clean and undamaged to maintain the integrity of the Hazardous Location construction.

2. Open Flex-Tone by removing the (8) nuts and bolts and lifting off housing cover. Keep mating surfaces of housing clean and undamaged for proper reassembly.



CAUTION

During installation, take care not to damage components on the printed circuit board.

3. Set miniature programming switches on the printed circuit board (Figure 2) for the desired tone. Set priority tone on SW1 and a secondary tone on SW2. Refer to tone program chart on inside cover and Table 1.
4. Check Flex-Tone label for proper operating voltage. Install power source and initiating circuit wires through a 1/2" (13 mm) conduit attached to an outlet box and nipple.

The outlet box, conduit and nipple must be suitable for the hazardous location with 1/2" (13 mm) -14 NPT threading at conduit openings. Outlet box, conduit and nipple are not supplied.

Remove cover from outlet box. Feed five numbered wires through a 1/2" (13 mm)-14 NPT nipple (not supplied) into the outlet box. Secure outlet box to Flex-Tone.

Connect green ground wire to earth ground.

Connect external wires to Flex-Tone wires as shown in Figure 4. Polarity must be observed for DC applications.

⚠ WARNING
Do not apply power to the unit until installation is completed and housing cover and outlet box cover are secured.

- Secure outlet box cover.
- The sound level is factory set to maximum. Adjust volume level, if desired, by turning potentiometer R72 (Figure 2).

- Adjust speaker direction by loosening (2) nuts and pivoting speaker to desired position (Figure 3). Tighten (2) nuts.
- Ensure mating surfaces are clean and undamaged. Secure housing cover aligning the straight edge of the cover with the straight edge of the housing. Torque nuts evenly in opposing pairs to 140 to 150 in-lb. Apply power.
- Verify operability.

Maintenance and Test

Examine the unit semi-annually for external accumulation of dirt. Clean if necessary.

The Flex-Tone should be tested annually or as required by the local authority having jurisdiction to ensure continuous service.

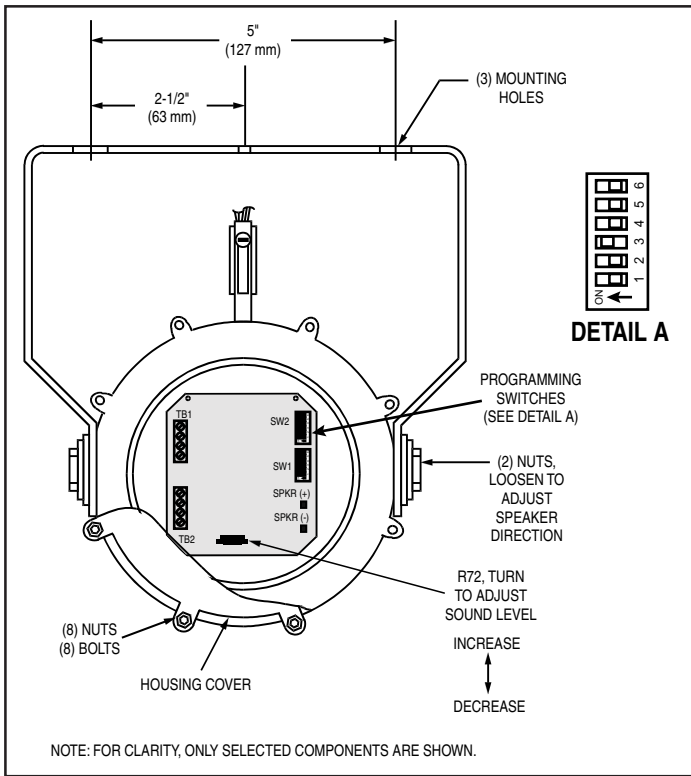

Figure 2. Flex-Tone PC Board and Mounting Holes, ETH855 Model Shown

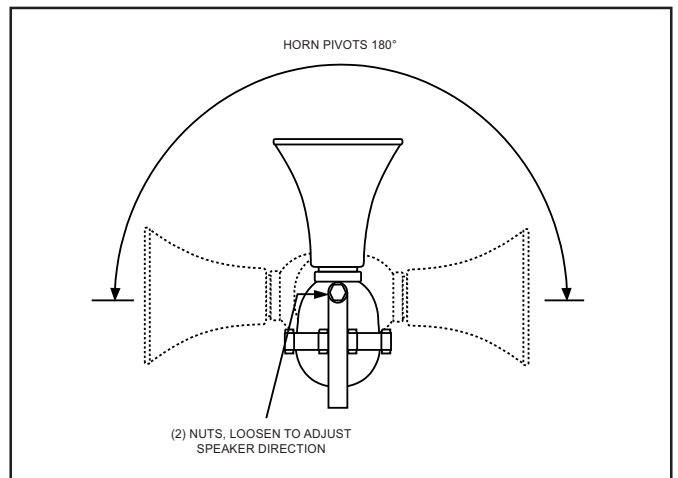

Figure 3. Speaker Adjustment

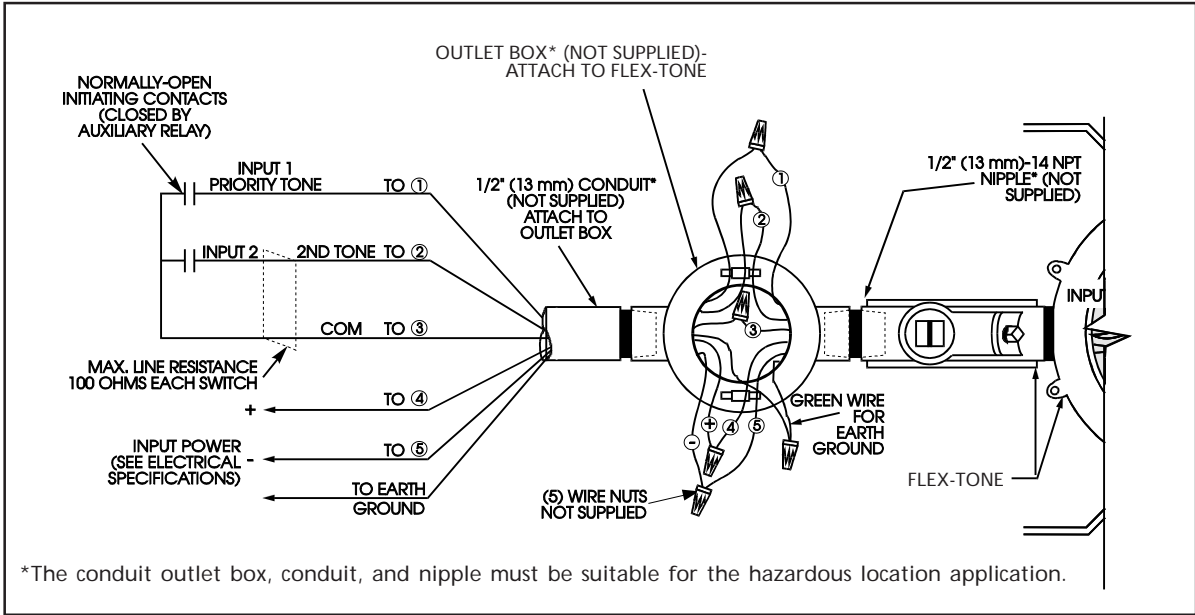
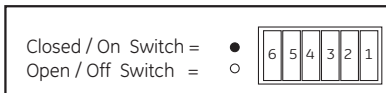

Figure 3. Wiring Diagram

Figure 15. Tone Programming

SWITCH POSITIONS	6 5 4 3 2 1	DESCRIPTION	HEX
No Tone	○ ○ ○ ○ ○ ○		00
Ding Dong	○ ○ ○ ○ ○ ●	Percussive pairs of 700 and 570 Hz tones each damped to zero	01
Warble	○ ○ ○ ○ ● ○	575 and 770 Hz alternately, 87 ms each	02
Siren	○ ○ ○ ○ ● ●	600-1250 Hz up and down sweep in 8 seconds and repeat	03
Stutter	○ ○ ○ ● ○ ○	Percussive 470 Hz, 83 ms on, 109 ms off	04
Slow Whoop	○ ○ ○ ● ○ ●	600-1250 Hz upward sweep in 4 seconds and repeat	05
Beep	○ ○ ○ ● ● ○	470 Hz, 0.55 seconds on, 0.55 seconds off	06
Chime 1	○ ○ ○ ● ● ●	700 Hz percussive repeat at 1 Hz	07
Fast Whoop	○ ○ ● ○ ○ ○	600-1250 Hz upward sweep in 1 second and repeat	08
Hi/Lo	○ ○ ● ○ ○ ●	780 to 600 Hz alternately, 0.52 seconds each	09
Rapid Siren	○ ○ ● ○ ○ ○	600-1250 Hz up and down sweep in 0.25 seconds and repeat	0A
Yeow	○ ○ ● ○ ● ●	1250 - 600 Hz downward sweep in 1.6 seconds and repeat	0B
Horn	○ ○ ● ● ○ ○	470 Hz continuous	0C
Air Horn	○ ○ ● ● ○ ●	370 Hz continuous	0D
Dual Tone	○ ○ ● ● ● ○	450 - 500 Hz, 0.4 to 0.5 second cycle	0E
Chime 2	○ ○ ● ● ● ●	575 Hz percussive repeat at 1 Hz	0F
Westminster	○ ● ○ ○ ○ ○	Two measures: 411 Hz, 520 Hz, 407 Hz, 312 Hz	10
Three Blind Mice	○ ● ○ ○ ○ ●	Four measures: 787 Hz, 714 Hz, 625 Hz, 952 Hz, 333 Hz	11
Phasor	○ ● ○ ○ ● ○	416 - 625 Hz up and down sweep in 13 ms and repeat	12
Telephone	○ ● ○ ○ ● ●	570 and 770 Hz alternately, 50 ms each for 1.2s, 1.5 s delay and repeat	13
Staircase	○ ● ○ ● ○ ○	440 - 2000 Hz up and down steps, 750 ms delay and repeat	14
3 Tone Alert	○ ● ○ ● ○ ●	463, 641 and 896 Hz, 200 ms each 1 second delay and repeat	15
RESERVED	○ ● ○ ● ● ○	RESERVED	16
RESERVED	○ ● ○ ● ● ●	RESERVED	17
RESERVED	○ ● ● ○ ○ ○	RESERVED	18
RESERVED	○ ● ● ○ ○ ●	RESERVED	19
RESERVED	○ ● ● ○ ● ○	RESERVED	1A
NFPA Whoop	○ ● ● ○ ● ●	Three 422 - 775 Hz upward sweeps, 850 ms each, 1s delay and repeat	1B
3 Pulse Horn*	○ ● ● ● ○ ○	470 Hz, 3 0.5s pulses separated by 0.5s followed by 1.5s delay and repeat	1C
3 Pulse Air Horn*	○ ● ● ● ○ ●	370 Hz, 3 0.5s pulses separated by 0.5s followed by 1.5s delay and repeat	1D
3 Pulse Dual Tone*	○ ● ● ● ● ○	450 - 500 Hz, 0.4 to 0.5s cycle, 3 0.5s pulses separated by 0.5s followed by 1.5s delay and repeat	1E
3 Pulse Chime 2*	○ ● ● ● ● ●	575 Hz, 3 0.5s pulses separated by 0.5s followed by 1.5s delay and repeat	1F
European Police	● ○ ○ ○ ○ ○	969 Hz and 800 Hz alternately 0.250 seconds each	20
European Fire	● ○ ○ ○ ○ ●	982 Hz and 864 Hz downward sweep in 0.134 seconds	21
European Slow Whoop	● ○ ○ ○ ● ○	658 Hz to 1312 Hz upward sweep in 3s followed by 0.5s delay and repeat	22
European General	● ○ ○ ○ ● ●	1087 Hz for 0.5 seconds followed by 0.5 second delay and repeat	23
European Toxic	● ○ ○ ● ○ ○	982 Hz continuous	24
European Police 2	● ○ ○ ● ○ ●	554 Hz and 440 Hz alternately 0.800 seconds each	25
European Stutter	● ○ ○ ● ● ○	3876 Hz for 0.146 seconds followed by 0.102 seconds delay and repeat	26
European Sweep	● ○ ○ ● ● ●	1315 Hz to 413 Hz downward sweep in 1.17 seconds and repeat	27
Telephone 2	● ○ ● ○ ○ ○	Alternate tones at 567 Hz and 326 Hz, for 0.052 seconds each	28
Buzzer	● ○ ● ○ ○ ●	1315 Hz to 746 Hz alternating for 0.003 seconds each	29
Genesis Horn Cont.	● ○ ● ○ ○ ○	Continuous Genesis horn	2A
Genesis Horn Temp.	● ○ ● ○ ● ●	Temporal Genesis horn	2B
Warning 1	● ○ ● ● ○ ○	1207 Hz and 493 Hz, alternately 0.002 seconds each	2C
Warning 2	● ○ ● ● ○ ●	2336 Hz and 493 Hz, alternately 0.005 seconds each	2D
Warning 2 Beep	● ○ ● ● ● ○	0.500s of 2336 Hz and 493 Hz each alternating for 0.005s followed by 1s delay	2E
Caution	● ○ ● ● ● ●	453 Hz for 0.040s, 235 Hz for 0.020s, 235 Hz for 0.160s, 260 Hz for 0.050s, 260 Hz for 0.1009s, 235 Hz for 0.050s	2F
Multi-tone	● ● ○ ○ ○ ○	376, 357, 352, 382, 355, 375, 384, 375 and 364 Hz alternately on for 0.050s	30
Attention	● ● ○ ○ ○ ●	2232, 4545, 3704, 2777, 4347, 3704, 2500 Hz alternately on for 0.003s	31
High Freq. Steady Alert	● ● ○ ○ ○ ○	2500 Hz continuous	32
High Freq. Fast Siren	● ● ○ ○ ● ●	2500 to 3048 Hz up and down sweep in 0.130 seconds	33
High Freq. Slow Siren	● ● ○ ● ○ ○	2500 to 3048 Hz up and down sweep in 0.500 seconds	34
DIN PFEER	● ● ○ ● ○ ●	Ramp downward from 1336 Hz to 522 Hz in 1.2 seconds and repeat	35
NFS 32 001	● ● ○ ● ● ○	584 Hz for 0.100 seconds and 461 Hz for 0.400 seconds	36
Ode to Joy	● ● ○ ● ● ●	6.45 seconds of melody followed by 1 second delay and repeat	37
Twinkle Little Star	● ● ○ ● ○ ○	13.2 seconds of melody followed by 1 second delay and repeat	38
Dueling Banjos	● ● ● ○ ○ ●	10.84 seconds of melody followed by 1 second delay and repeat	39
La Cucaracha	● ● ● ○ ● ○	7.10 seconds of melody followed by 1 second delay and repeat	3A
Yellow Rose of Texas	● ● ● ○ ● ●	19.34 seconds of melody followed by 1 second delay and repeat	3B

*3 Pulse Tones are for Evacuation Use Only.



⚠ CAUTION

The use of evacuation signals on this product, that is not specifically Listed for Fire Alarm Use, is subject to the approval of the Authority Having Jurisdiction.

P/N 3100881 OFFSET SPEC

INSTALLATION INSTRUCTIONS FOR FLEX-TONE
SPEAKER/AMPLIFIERS

(1) 11" X 17" SHEET PRINTED BOTH SIDES. FOLD
THREE TIMES TO DIMENSIONS SHOWN WITH
PART NUMBER ON THE OUTSIDE.

MATERIAL: STANDARD WHITE OFFSET STOCK
CHARACTERS: TO BE BLACK ON WHITE BACK-
GROUND

NOTE: MECHANICALS HAVE ALREADY BEEN
REDUCED TO ACTUAL SIZE.

ECN: 05-C1764
FILE: 3100881
ISSUE: 1
APPROVED: AA

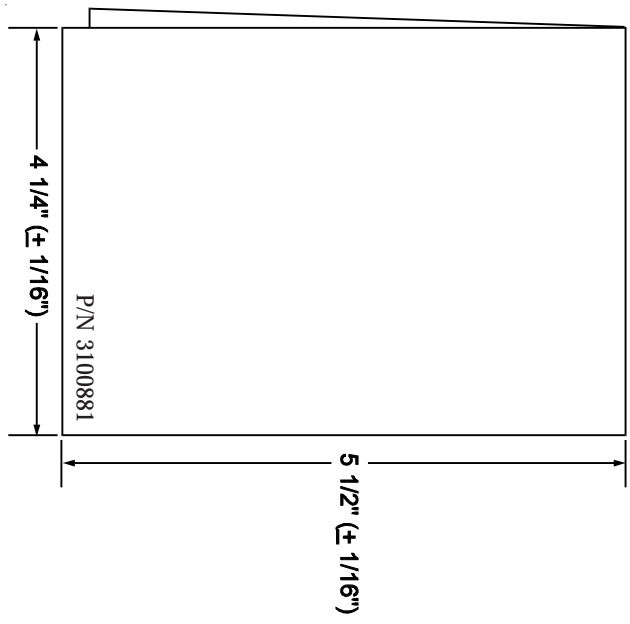

All statements, technical information and recommendations contained herein are based on information and tests we believe to be reliable. The accuracy or completeness thereof are not guaranteed. In accordance with Crouse-Hinds "Terms and Conditions of Sale", and since conditions of use are outside our control, the purchaser should determine the suitability of the product for his intended use and assumes all risk and liability whatsoever in connection therewith.
