



# SERVICE PARTS LIST

**BULLETIN NO.**  
54-24-2663

SPECIFY CATALOG NO. AND SERIAL NO. WHEN ORDERING PARTS		REVISED BULLETIN 54-24-2662	DATE June 2015
<b>M18 FUEL™ COMPACT 1/2" HAMMER-DRILL</b>			
CATALOG NO.	<b>2604-20</b>	STARTING SERIAL NO.	<b>D56D</b>
WIRING INSTRUCTION			

**EXAMPLE:**  
Component Parts (Small #) Are Included  
When Ordering The Assembly (Large #).

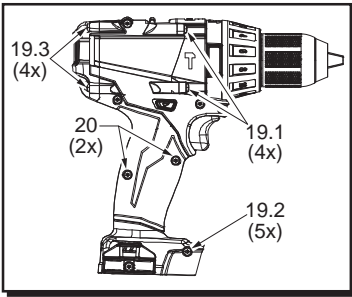

Apply Red Loctite® thread locking sealant or the equivalent to the threads of the gearcase spindle (3) before securing chuck to that spindle. Torque to 550-600in/lbs (45-50ft/lbs).

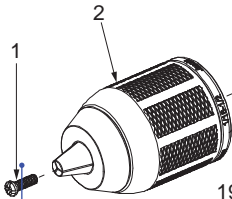

Apply Blue Loctite® thread locking sealant or the equivalent to the threads of the chuck screw (1) before securing chuck to the gearcase spindle. Torque to 90-100in/lbs (7-8ft/lbs).

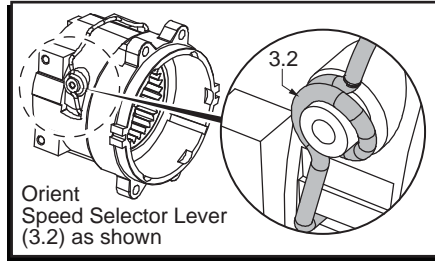
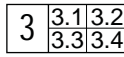

Orient Speed Selector Lever (3.2) as shown

FIG.	PART NO.	DESCRIPTION OF PART	NO. REQ.
1	05-88-1500	M6 x 1.0 LH Chuck Screw w/ locking patch	(1)
2	42-66-0215	1/2" Keyless Chuck	(1)
3	14-29-2604	Gearcase Assembly	(1)
3.1	05-81-0542	M2.3 x 4.5mm ST Screw	(2)
3.2	44-10-2603	Speed Selector Lever	(1)
3.3	-----	2.3 x 34 Pin	(2)
3.4	-----	Motor Mounting Plate	(1)
4	45-24-2603	Speed Selector Button	(1)
★ 5	42-42-2803	Forward / Reverse Shuttle	(1)
★ 6	31-44-2803	Housing Kit	(1)
6.1	-----	Right Housing Halve	(1)
6.2	-----	Left Housing Halve	(1)
6.3	-----	Rear Cap	(1)
★ 7	14-20-2804	Housing / Electronics Kit	(1)
7.1	-----	Motor / Switch / PCBA Assembly	(1)
8	16-07-2603	Service Armature	(1)
9	42-55-2604	Blow Molded Carrying Case	(1)
10	42-62-0526	Auxiliary Side Handle Assembly	(1)
11	40-50-1135	Shuttle Spring	(1)
12	12-20-2604	Service Nameplate	(1)
★ 13	42-42-2804	Forward / Reverse Shuttle Kit	(1)
19.1	06-82-6350	M3 x 16mm T-10 ST Screw (Gearcase)	(4)
19.2	06-82-6350	M3 x 16mm T-10 ST Screw (Handle Halves)	(5)
19.3	06-82-6350	M3 x 16mm T-10 ST Screw (Rear Cap)	(4)
20	06-82-1080	M3 x 14mm T-10 ST Screw (Handle Halves)	(2)
21	42-70-2653	Belt Clip Assembly	(1)
22	06-82-0130	6-32 x 5/16" Pan Hd. T-15 Machine Screw	(1)
23	-----	Belt Clip	(1)
30	23-94-2125	220mm Wire Assy. with Terminal (High Voltage Protection, See Page 2)	(1)
40	22-56-0150	Closed End Connector	(1)

★ = Part number change from previous service parts list.

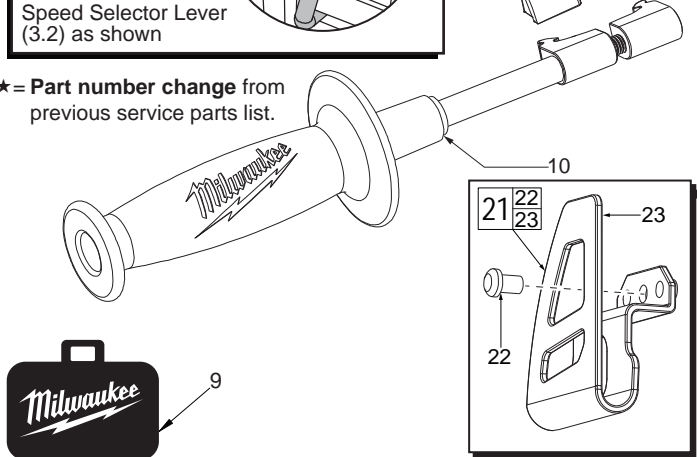

SCREW TORQUE SPECIFICATION CHART				
FIG.	PART NO.	DESCRIPTION	SEATING TORQUE (IN-LBS) (FT-LBS)	
1	05-88-1500	Chuck Screw	90-100	7-8
2	42-66-0215	1/2" Keyless Chuck	550-600	45-50
3.1	05-81-0542	Speed Selector Lever Screw	3.5±1	
19.1	06-82-6350	Gearcase Assembly Scr	7.0±2.5	
19.2	06-82-6350	Right Housing Halve Scr (Qty. 5)	7.0±2.5	
19.3	06-82-6350	Rear Cap Screw	4.0±1	
20	06-82-1080	Right Housing Halve Scr (Qty. 2)	7.5±2.5	

**MILWAUKEE ELECTRIC TOOL CORPORATION**  
13135 W. Lisbon Road, Brookfield, WI 53005  
Drwg. 1

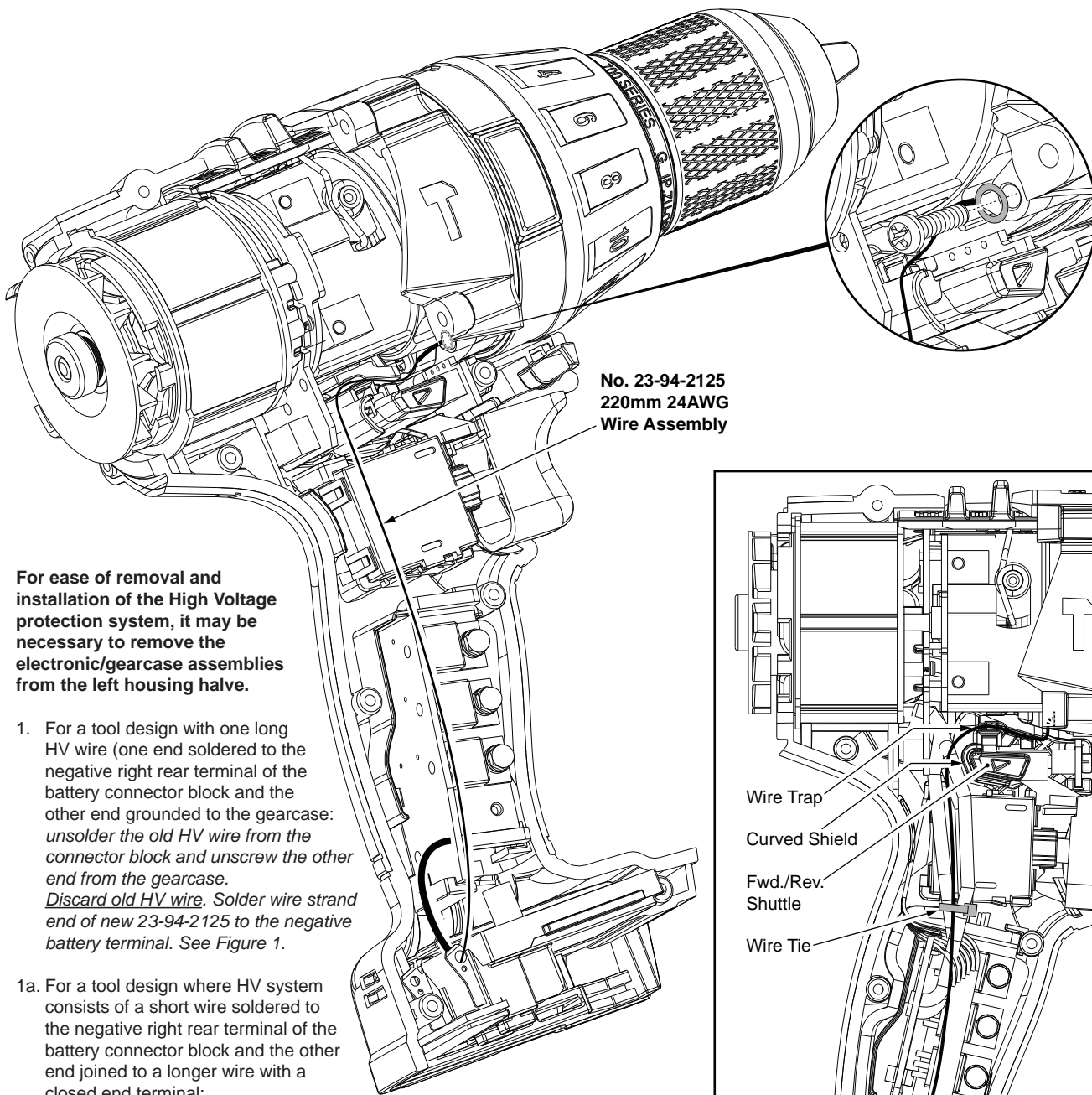

No. 23-94-2125  
220mm 24AWG  
Wire Assembly

For ease of removal and installation of the High Voltage protection system, it may be necessary to remove the electronic/gearcase assemblies from the left housing half.

1. For a tool design with one long HV wire (one end soldered to the negative right rear terminal of the battery connector block and the other end grounded to the gearcase: *unsolder the old HV wire from the connector block and unscrew the other end from the gearcase. Discard old HV wire. Solder wire strand end of new 23-94-2125 to the negative battery terminal. See Figure 1.*
- 1a. For a tool design where HV system consists of a short wire soldered to the negative right rear terminal of the battery connector block and the other end joined to a longer wire with a closed end terminal: *use a side cutter or similar tool to snip the end off of the closed end connector. Unscrew the long wire from gearcase. Discard old HV long wire and connector. Twist the wire strand end of the new 23-94-2125 to the wire strands of the short wire on the battery connector block. Secure both wires with a new closed end connector (22-56-0150). See Figure 2.*
2. Place Electronic/Gearcase Assemblies loosely into the housing support (left housing half).
3. Route the wire through wire traps above the fwd./rev. shuttle and around the curved shield behind the shuttle.
4. Route the wire over the three wires on the right side of switch and thread wire through existing wire tie (See detail to the right). **Note:** If wire tie is too tight to slip high voltage wire through, carefully snip that wire tie off and replace with a new small wire tie (23-78-0100) to secure all four wires right below the switch.
5. Place the ring terminal of the new HV wire assembly over the hole in gearcase. Orient the terminal so wire feeds to the left across the bottom of the gearcase and secure with the gearcase screw.

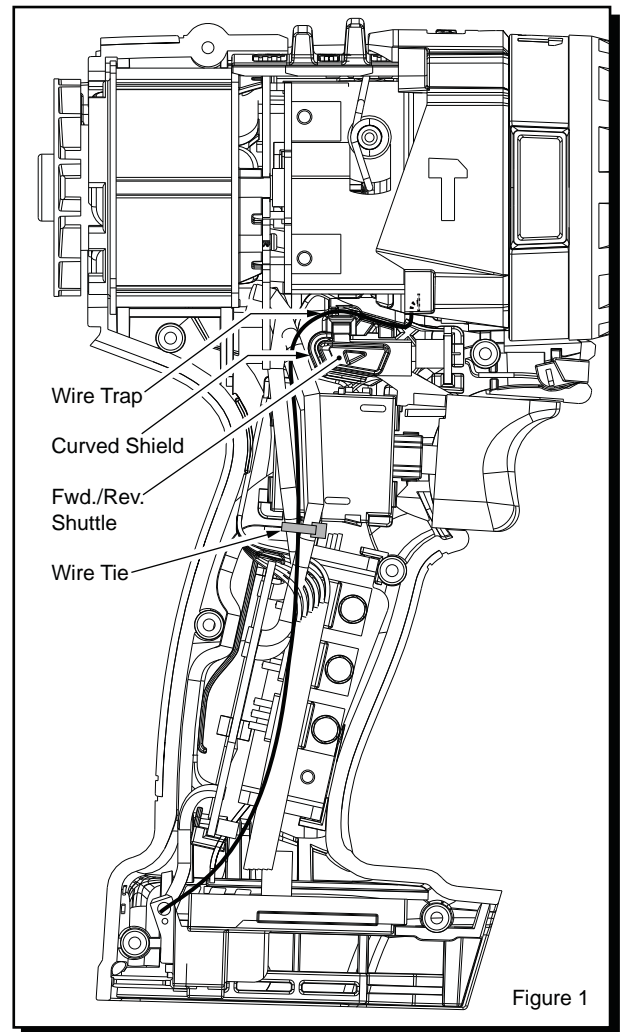

Figure 1

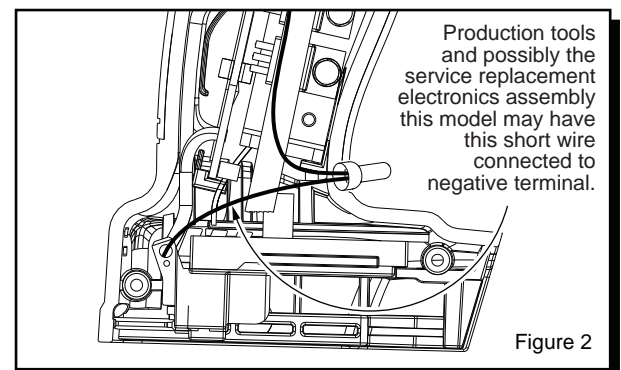

Figure 2

Production tools and possibly the service replacement electronics assembly this model may have this short wire connected to negative terminal.